



Customer / 客户: TBD

Number/文件编号: TBD

Cylindrical Li-ion Battery Specifications

圆柱型锂离子电池规格书

Model No. / 型号: ICR18650-26J-4S6P

Approved by/ Date 批准/日期	Checked by/ Date 审核/日期	Prepared by/Date 编制/日期

History of revisions 修订记录				
Edition 版本	Description 描述	Prepared by 编制	Approved by 批准	Date 日期
临时版	临时版	CYJ	Cuibohu	2020-09-08

环保要求: ROHS 2.0 REACH 无卤

SHEN ZHEN KAYO BATTERY CO., LTD.

深圳市嘉洋电池有限公司

Tel: +86-755-28117967, Fax: +86-755-28117957

The 3th,11# Building, HuaLian Industrial Park, HuaNing Road, DaLang Community, LongHua Town, Shenzhen, P.R.China

深圳市龙华新区大浪街道华宁路华联工业区 11 栋 3 楼

www.kayobattery.com

Note: 1. Please kindly sign on the underneath and send it back to us if the samples have been approved.
请帮忙在下面客户确认栏中签名并回传，如果样品通过了客户的测试。
2. Please kindly contact us as soon as possible if the samples can't be approved. Thanks!
请尽快与我们联系，如果样品没有通过客户的测试。谢谢！

Client Confirmation 客户确认	



Date / 日期	
-----------	--

Contents / 主要内容

1.Product Summary / 产品概要-----	3
2.Product configurations / 产品组成-----	3
3.Product Dimensions / 产品结构-----	3
4.Product Specifications / 产品规格-----	6
5.Product Performance / 产品电性能-----	6
6.PCM Specifications / 保护板规格-----	9
7.Security Test / 安全测试-----	11
8.Storage and Transportation / 储存与运输-----	12
9.Use Attentions / 使用注意事项-----	13
10.Warranty / 品质保证-----	13
11.Others / 其它事项-----	14
12.Note / 通知-----	14
13.Accessor/附件-----	15

1. Product Summary / 产品概要

1.1 Standard / 依据标准

This product complies with National Standard GB31241-2014 《Lithium ion cells and batteries used in portable electronic equipments-Safety requirements》.

本产品依据标准：中华人民共和国国家标准 GB31241-2014 《便携式电子产品用锂离子电池和电池组安全要求》

1.2 Sphere of application / 适用范围

This specification is applied to ICR18650-26J-4S6P battery Manufactured by SHEN ZHEN KAYO BATTERY Co., Ltd.

本规格书是由深圳市嘉洋电池有限公司制作提供，适用的电池型号是 ICR18650-26J-4S6P。

2. Product Configurations / 产品组成

No. 序号	Item 项目	Components Descriptions 零件描述	Remark 备注
1	Cylindrical Li-ion Cell 圆柱型锂离子电芯	ICR18650-26J	SDI
2	PCM / 保护板	R5650T402AA+CJAE55N03*4	
3	Shell 壳体	ABS+PC	

3. Product Dimensions / 产品结构

3.1 Pack Drawing / 电池尺寸图

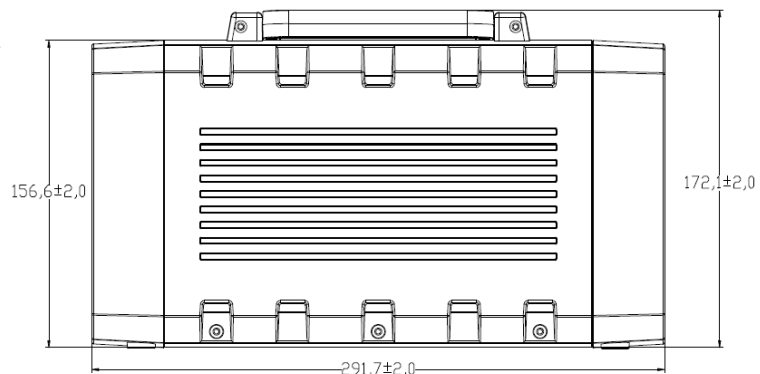
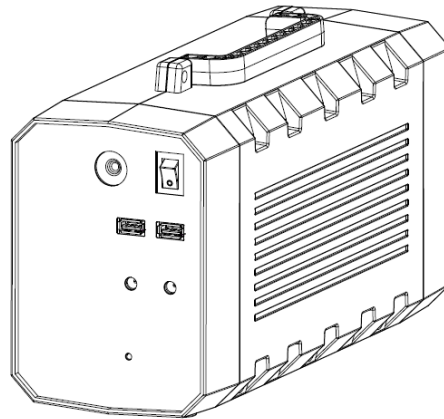

3.2 Label / 标贴

4.Product Specifications / 产品规格

Table 1 / 表 1:

No. 序号	Item 测试项目	Performance 性能参数		Remark 备注
1	Capacity 容量	Typical/ 典型	15.6Ah	Discharge at 0.2C to 12.0V after standard charge. 标准充电后, 使用 0.2C 的电流放电到 12.0V。
		Minimum / 最小值	14.5Ah	
2	Nominal Voltage 标称电压	14.52V		Operation voltage during standard discharge. 标准放电过程的工作电压值
3	Cut-off Voltage 放电终止电压	12V		
4	Charging Voltage 充电电压	16.8V		
5	Internal Impedance 内阻	≤150mΩ		AC 1KHz after standard charge 标准充电后 AC 1KHz 测试
6	Standard Charge 标准充电	CC / CV: 16.8V / 0.2C charging till to the current decline to 0.02C, at 23°C. 恒流 / 恒压: 16.8V / 0.2C 充电直到电流下降到 0.02C, 环境温度 23°C		Charge time: Approx 6.5h. 充电时间: 大约 6.5 小时
7	Standard Discharge 标准放电	Discharge continuously with 0.2C to 12V. 使用恒流 0.2C 的电流连续放电到 12V。		
8	Fast Charge 快速充电	CC / CV: 16.8V / 5A charging till to the current decline to 0.02C, at 23°C. 恒流 / 恒压: 16.8V / 5A 充电直到电流下降到 0.02C, 环境温度 23°C		Charge time: Approx 3.5h. 充电时间: 大约 3.5 小时
9	Fast Discharge 快速放电	Discharge continuously with 0.5C to 12V. 使用恒流 0.5C 的电流连续放电到 12V。		
10	Max. Charge Current 最大充电电流	5A		
11	Max. Continuous Discharge Current 最大连续放电电流	0.5C		
12	Operation Temperature 工作温度	0~+10°C	≤0.2C恒流充电 ≤ 0.2C constant current charging	Charge 充电
		10~+45°C	≤5A恒流充电 ≤ 5A constant current charging	
		-20~+10°C	≤0.2C恒流放电	Discharge 放电

			$\leq 0.2C$ constant current discharging $\leq 0.5C$ 恒流放电 $\leq 0.5C$ constant current discharging	
		10~+60°C		
13	Storage Temperature 储存温度	Less than 1 year: -20~+25°C 少于 1 年: -20~+25°C		Recommend to charge and discharge at least 1 time to maintain battery. 建议至少要对电池进行一次充放电, 进行电池性能维护。
		Less than 6 months: -20~+30°C 少于 6 个月: -20~+30°C		
		Less than 3 months: -20~+40°C 少于 3 个月: -20~+40°C		
14	Storage Humidity 储存湿度	65±20% RH		
15	Weight 重量	Approx: TBD 大约 TBD		
16	Product Dimensions 产品尺寸	Length: 291.7±2.0mm 长度: 291.7±2.0mm		Initial battery dimensions 初始电池尺寸
		Width: 172.1±2.0mm 宽度: 172.1±2.0mm		
		Diameter: 156.6±2.0mm 直径: 156.6±2.0mm		
17	Ex-Factory Voltage 出厂电压	14.4-15.8V		About 30%-70% power 约 30%-70% 电量

5. Product Performance / 产品电性能

5.1 Standard Testing Conditions / 标准测试条件

Unless otherwise stated, tests should be done within one month of delivery under the following conditions:

- * Initial batteries: less than 5 cycles
- * Relative humidity: 45~85% RH
- * Ambient Temperature: 23±3°C
- * Notes on standard charge / discharge condition

除非其它规定, 测试应该在出货一个月内进行测试, 遵循以下测试条件要求:

- * 新生产电池: 少于 5 次循环以下
- * 相对环境湿度: 45~85% RH
- * 环境温度: 23±3°C

5.2 Measuring Instrument / 测量仪器

5.2.1 Dimension Measuring Instrument / 尺寸测量仪器

The dimension measurement shall be implemented by instruments with equal or more precision scale of 0.01mm.

尺寸测量应使用测量精度达到 0.01mm 或以上测试仪器。

5.2.2 Voltmeter/ 电压表

Standard class specified in the national standard or more sensitive class having inner impedance more than 10kΩ/V.

国家标准或更高灵敏度等级电压表, 仪器内部阻抗 ≥ 10kΩ/V。

5.2.3 Ammeter / 电流表

Standard class specified in the national standard or more sensitive class. Total external resistance including ammeter and wire is less than 0.01Ω.

国家标准或更高灵敏度等级电流表，仪器总阻抗≤0.01Ω。

5.2.4 Internal Impedance Meter / 内阻测量仪

Impedance shall be measured by a sinusoidal alternating current method (AC 1kHz LCR meter).

内阻测试仪测试方法为交流脉冲阻抗法(AC 1kHz LCR)。

5.3 Standard Charge and Discharge / 标准充电和放电

5.3.1 Standard Charge / 标准充电:

Lithium ion battery charging method: Constant Current / Constant Voltage (CC/CV)

锂离子电池充电方法: 恒流/恒压充电(CC/CV)

Standard charge current: 0.2C =3.12A

标准充电电流: 0.2C =3.12A

Charge voltage: 16.8V

充电电压: 16.8V

Use 0.2C constant current to charge batteries, convert to use 16.8V constant voltage to charge when the batteries voltage achieves 16.8V at 23 ±3°C. Cut off charging when the charging current decline to 0.02C

在 23±3°C环境温度下，先使用 0.2C 恒定电流给电池充电，在电池电压上升到 16.8V，转用 16.8V 恒定电压充电，当充电电流下降到 0.02C 时，终止充电。

5.3.2 Standard Discharge / 标准放电

Standard discharge current: 0.2C =3.12A

标准放电电流: 0.2C =3.12A

Batteries should be discharged with constant current 0.2C to 12V at 23 ±3°C.

电池标准放电应在 23 ±3°C 的环境温度中，使用 0.2C 的恒定电流连续放电到 12V。

5.4 Appearance / 外观

The cell / battery shall be free from cracks, scars, breakage, rust, discoloration, leakage and deformation.

电池外观应平整，洁净完好，不能有褶皱，刮伤，锈斑，漏液等等。

5.5 Performance Test / 电性能测试

Table 2 / 表 2:

Item 测试项目	Test Conditions 测试条件	Requirements 标注要求
Open-Circuit Voltage 开路电压	Within 24 hours after standard charge. 充满电后 24 小时内	≥12.4V
Internal Impedance 内阻	Upon fully charge (1kHz LCR meter). 电池充满电的情况下，使用 1KHz 的交流脉冲内阻测试仪。	≤150mΩ
Capacity 容量	Standard Charge and Discharge to 12V 标准充电后放电至 12V	≥14.5Ah

5.6 Temperature Performance / 温度性能

Batteries should be standard charged, and stored in temperature as below of table 3 for 3hours, and then discharge batteries to 12V with 0.2C at relative temperature. The expectation of discharge capacity percentage as below of table 3 compare to nominal capacity.

电池标准充满电后，储存于如表 3 的温度值中 3 小时，然后在此温度下使用 0.2C 的电流放电到 12V.电池的放电容量与电池标称容量的百分比如表 3。

Table 3 / 表 3:

Temperature 温度	-10℃	0℃	23℃	40℃
Capacity Percentage 容量百分比	60%	80%	100%	95%

5.7 Cycle Life and Leakage Test / 循环寿命和漏液测试

Table 4:

No. 序号	Item 项目	Criteria 标准要求	Test Conditions
1	Cycle Life 循环寿命测试	≥500 cycles ≥70% of the Initial Capacity ≥70%的初始容量	1. Standard charge / 标准充电 2. Rest 30minutes / 搁置 30 分钟 3. Discharge: 0.5C to 12V/ 放电:0.5 C 放电至 12V 4. Rest 30minutes / 搁置 30 分钟 5. Recycles step 1~ step 4 till to 500 cycles at 23±3℃/ 重复按照步骤 1~步骤 4 的测试 500 循环, 在 23±3℃的 环境温度中
2	Leakage 漏液测试	No leakage 无漏液	fully charge, store at 60±3℃, 60±10%RH for 1week. 电池满充电后, 储存在 60±3℃, 60±10%RH 的环境中 1 周。

6. PCM Specifications / 保护板规格

6.1 Using scope: The specifications apply to Li-ion Battery Protection Module for KAYO Company.

保护板规格适用于嘉洋公司锂离子电池保护板要求。

6.2 Battery capacity: 15.6Ah

电池容量: 15.6Ah

6.3 Environment request: RoHS2.0.

环保要求: 符合 RoHS2.0

6.4 Function description: Over charge protection, Over discharge protection, Over current protection

Short circuit protection

保护板功能描述: 过充电保护, 过放电保护, 过电流保护和短路保护。

6.5 Electric features / 电气属性:

以下参数测试均在温度 25±3℃, 湿度 65±25% RH 环境下进行 (超过此范围测量会有误差)

Item 项目	Parameter value 参数值			Unit 单位
	Min. 最小	Typical 典型	Max. 最大	
over charge protection voltage 过充电保护电压	4.225	4.250	4.275	V
over charge release voltage 过充电恢复电压	4.10	4.150	4.20	V
over discharge protection voltage 过放电保护电压	2.65	2.7	2.75	V
over discharge protection release voltage 过放电恢复电压	2.900	3.000	3.100	V

Discharge over current protection current 过流保护电流	10	15	20	A
Discharge over current protection delay time 过流保护延迟时间	6	9	15	ms
Charge over current protection current 过流保护电流	5	7.5	10	A
Charge over current protection delay time 过流保护延迟时间	6	9	15	ms
over charge protection delay time 过充电保护延迟时间	0.7	1.0	1.3	s
over discharge protection delay time 过放电保护延迟时间	83	119	155	ms
short protection delay time 短路保护延迟时间	300	500	700	μs
current consumption (power on) 保护板自耗电电流 (工作状态)	/	/	25	μA
current consumption (power down) 保护板自耗电电流 (睡眠状态)	/	/	9	μA
Impedance 保护板内阻	/	/	50	mΩ
DC input	16.8V 3A			
DC output	12V 2A			
USB	5V 2A			

6.6 Reliability test / 可靠性测试

6.6.1 Humidity test: 40±2°C, 90%RH, 48h

湿度测试: 40±2°C, 90%RH, 48h

6.6.2 High temp. test: 55±2°C, 2h

高温测试: 55±2°C, 2h

6.6.3 Low temp. test: -20±2°C, 16h

低温测试: -20±2°C, 16h

6.6.4 ESD test: It can service perfectly after ± 4KV directly contact and ± 8KV air condition

静电测试: 经过± 4KV 直接接触测试和± 8KV 空气间隔测试, 元件仍然能正常工作。

6.7 PCB Layout / 电路板布局:

6.8 Circuit diagram / 电路原理图:

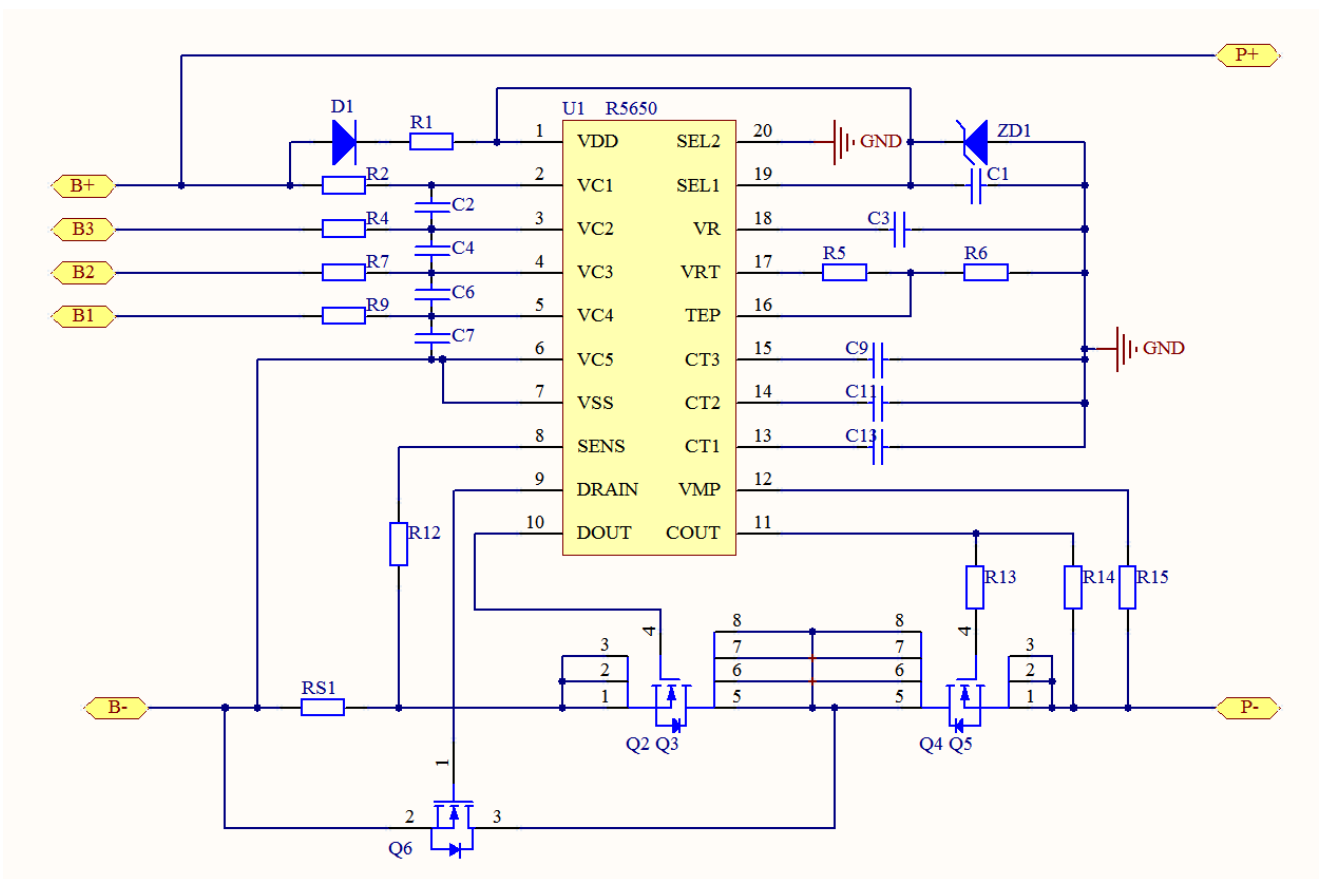

6.9 Key Parts list / 关键元件清单:

Name / Vendor 名称 / 厂商	Symbol 符号	Model No. / Spec. 物料规格	Unit 单位	Qty 数量
保护 IC	U1	R5650T402AA,3/5 节 保 护 IC,TSSOP20,HF,RICOH	pcs	1
MOS	Q2-Q5	CJAE55N03,N-Channel, PDFNW5*6-8L,HF,JCET	pcs	4
贴片二极管	D1	IN4148WS,二极管,100V,SOD-323,ROHS,长电	pcs	1
稳压二极管	ZD1	SMD,BZT52C30S,30V,SOD-323,长电, ROHS	pcs	1
MOS	Q6	2N7002K,Single-N,SOT-23,ROHS,长电	pcs	1
合金电阻	RS1	2512,2mΩ, ±1%, 2W, HF, 元宝	pcs	1

7.Security Test (Cell) / 安全测试(电芯)

Item 项目	Conditions 条件要求	Test Method 测试方法	Requirements 标准要求
Over charge 过充电测试	Initial, Fully Charged 新生产, 充满电电池	CC / CV: 4.60V / 3C charging for 8hrs 恒流/恒压: 4.60V/3C 充电 8 小时	No explosion, No fire 不爆炸, 不起火
Over discharge 过放电测试	Initial, Fully Charged 新生产, 充满电电池	Discharge at 0.5C to 2.75V, and then at 0.2C to 0V. 先用 0.5C 放电到 2.75V, 再转 0.2C 放电到 0V	No explosion, no fire 不爆炸, 不起火
Heat shock 热冲击测试	Initial, Fully Charged 新生产, 充满电电池	Put batteries in a oven, start at 25°C, temperature raises 5°C/min, till to 130°C, and then remains for 30 minutes. 把电池放置在烤箱中, 以 5°C/分钟的温升加温, 直到烤箱温度达到 130°C, 然后保持 30 分钟。	No explosion, No fire 不爆炸, 不起火
Crush 挤压测试	Initial, Fully Charged 新生产, 充满电电池	Crush between two flat plates. Applied force is about 13KN (1.72Mpa) for 10min. 用两平板夹住电池, 使用 13KN (1.72Mpa)的压力挤压电池, 保持 10 分钟。	No explosion, No fire 不爆炸, 不起火
Short Circuit 短路测试	Initial, Fully Charged 新生产, 充满电电池	Batteries are to be short-circuited by connecting positive and negative terminals of battery with copper wire having a maximum resistance load of 0.1Ω. 用电阻少于 0.1Ω 的铜导体直接短接电池外部的正负极。	No explosion, No fire Top temp. not exceed 150°C 不爆炸, 不起火, 电池最高温度不超过 150°C。
Vibration 振动测试	Initial, Fully Charged 新生产, 充满电电池	Batteries are to be tested as following conditions: Amplitude: 1.6mm Frequency:10~55Hz(sweep:1Hz/min) Direction: X/Y/Z axis for 30min. The batteries are to be tested in three mutually perpendicular to each axis. 电池应按照以下条件进行测试: 振幅: 1.6mm 频率: 10~55Hz(以 1Hz/min 提高频率) 方向: 以 X/Y/Z 为主轴, 向三个方向交互震动 30 分钟	No fire, no explosion 不爆炸, 不起火

8. Storage and Transportation / 储存与运输

8.1 Storage / 储存:

8.1.1 The Li-ion battery should be stored in a cool, dry and well-ventilated area. Keep away from fire and heat.

锂离子电池应被储存于比较清凉, 干燥, 通风的环境中, 应远离火源和高温的地方。

8.1.2 The best capacity in storage is 30%-70% (voltage between 3.6-3.9V).

最佳储存的条件是电池带电量为 30%-70% (电压 3.6-3.9V)。

8.1.3 The battery should be stored in the specified temperature range, and according to the requirements of this specification for 3 months for 1 full charge and discharge and fill to 70% power.

电池应按照本规格书指定的储存要求存放, 并按照本规格书要求 3 个月进行 1 次完整充放电并补电至 70%电量。

8.2 Transportation / 运输:

8.2.1 Do not mix the battery with other cargos.

不要将电池与其它货物混装。

8.2.2 Do not immerse the battery in water or get it wet.

不要将电池浸入水中, 或者使电池潮湿。

8.2.3 Do not stake batteries over 7 layers and upside-down.

不要将电池叠放超过 7 层, 或者倒置电池方向。

8.2.4 Do not transport the battery when the ambient temperature is higher than 65°C.

不要在环境温度高于 65°C 时运输电池。

9. Use Attentions / 使用注意事项:

To ensure to use battery properly, please read the specifications carefully.

为保证正确使用电池, 请仔细阅读以下注意事项。

9.1 处理方法:

9.1.1 Do not dispose of the battery in fire or expose to the heat.

不要把电池丢入火中, 或者暴露在产生热源的地方。

9.1.2 Do not connect battery in charger or equipment with reverse positive and negative terminals.

不要把电池的正、负极反接在充电器或者用电设备上。

9.1.3 Do not short circuit the battery

不要使电池短路。

9.1.4 Do not make battery in physical shock or vibration.

不要冲击或者震动电池

9.1.5 Do not disassemble battery.

不要解剖电池。

9.1.6 Do not immerse battery in water or get it wet.

不要把电池浸入水中或者使电池受潮。

9.1.7 Do not use batteries mixed with other different type, model.

不要把不同型号, 不同批次和不同生产厂商的电池混合在一起使用。

9.1.8 Keep battery away from children.

远离儿童, 不要让儿童拿到。

9.2 Charge / 充电:

9.2.1 Battery must be charged in appropriate charger.

电池必须正确使用充电器充电。

9.2.2 Do not use modified or damaged charger.

不要使用被改装过的或者损坏的充电器。

9.2.3 Do not use unqualified with the specified charger.

不要使用不符合本规格书要求的充电器。

9.3 Discharge / 放电:

9.3.1 Do not discharge battery with surpassing current of specified.

不要使用超出本规格书指定的规格放电。

9.3.2 Do not discharge battery when the ambient temperature is out of the specified.

不要超出本规格书指定的放电温度范围给电池进行放电。

9.3.3 Do not over discharge battery.

不要对电池进行过度放电。

9.4 Disposal /废弃电池管理:

Dispose of batteries appropriately according to local regulations different from other countries.

按照不同国家的废弃电池管理规则进行正确丢弃，合理回收废弃电池。

10. Warranty / 品质保证

The battery warranty time is 12 months, but kayobattery won't take any responsibility for the case of using the batteries out of this spec and request environment.

12个月的电池保质期，在本规格书规定环境之外使用电池发生的意外，本公司不承担责任。

11. Others/ 其它事项

Because batteries utilize a chemistry product, battery should be used and stored appropriately.

Otherwise, it maybe leads to battery performance decline; even so, it can be deteriorated, damaged, electrolyte leakage. So, please read the specifications carefully when using, storage or transportation, and keep maintaining battery according to the specifications.

电池属于电化学产品，电池应遵循本规格指定规格合理使用和储存。否则，可能会导致电性能下降，漏液，损坏，甚至或者产生危险。在使用前，消费者务必先仔细阅读本规格书，或者向我司咨询，保证消费者能够正确使用电池产品和进行有效维护。

12. Note / 通知

Any other items which are not covered in the specifications and it shall be referenced to relative standard and consulted by vendor and customer.

其它项目不包含在本规格书时，应参照有关行业标准或者得到供货商和采购商的协商认可。